Megatome

Large Tissue Embedding Protocol

Revision 202502



Table of Contents

Introduction	2
Gel embedding	3
Formalin fixation	4
Sample mounting on the Megatome	5

Introduction

This document describes the protocol recommended for preparing large samples (height of the sample > 15mm) for Megatome tissue sectioning, using the sample embedding toolkits included in your Megatome device. Due to the substantial dimensional variance of biological samples, the toolkits are designed with three different sizes. (For example, one can choose the **Small** toolkit for embedding a marmoset brain sample, the **Medium** toolkit for a pig brain sample, and the **Large** toolkit for a whole human hemisphere sample. Please note that the Large toolkit is not included for Megatome Standard version). This protocol works with PFA fixed samples.

The general protocol is as follows:

1. Gelatin embedding
2. Formalin fixation
3. Sample mounting on the Megatome

Chemicals needed:

- Gelatin powder (e.g. G6650 Sigma Aldrich)
- 10% Neutral Buffered Formalin (e.g. EpreDia™ 5735)
- 10X Phosphate-Buffered Saline (e.g. J62692.K3 Thermo Scientific Chemicals)

Toolkits include:

- ⑪ Lifting tray x 3*
- ⑫ Gelling container x 3*
- ⑬ Sample plate x 3*
- ⑮ 100 mm long stainless steel blade x 10
- ⑰ Fixation container x 3*
- ⑲ Velcro hooks with adhesive backing, 2" wide x 5' long

* 3 sets of accessory parts in small, medium and large sizes.

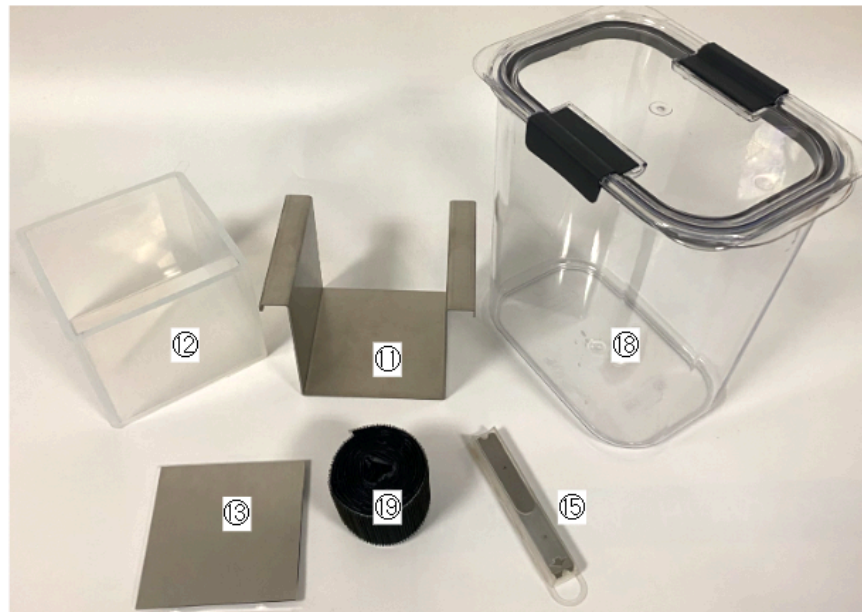

Figure 1 The Sample embedding toolkit

Gel embedding

Though agarose tissue embedding or non-embedding is possible for small and medium sample sectioning (depending on the sample orientation), it is not sufficient for sectioning an entire large sample continuously with the best quality for downstream image reconstruction/analysis. It's important to secure the position of the sample during the entire sectioning process.

1. Trim the **Velcro hook tape** and tape it on the top side of the **sample plate**.
2. Make **5-8% gelatin solution** by mixing gelatin powder with **1x PBS solution**. Heat the mixture in a microwave or on a hot plate until gelatin resolves completely. The gel solution should be clear without any clumps. The volume of the gel solution depends on the size of the toolkit and the size of the sample, the approximate volume to fill each gelling container is as below:

Toolkit size	Small	Medium	Large
Volume of gelatin solution	200 mL	500 mL	1800 mL

3. Assemble the toolkit. For coronal sectioning, place the **sample plate** to the side of the container (Figure 2a); for horizontal and sagittal sectioning, place the sample plate on the bottom of the container (Figure 2b).

4. Pour the gel solution into the assembled toolkit to about **5-10mm high**. Cover the container with aluminum foil, wait for 0.5 hour or until the gel solidifies. Cover the leftover gel solution and leave it in a 45°C incubator.
5. After the first layer of gel solidifies, place the sample in the container on top of the gel (Figure 2c). Pour the leftover gel solution into the container to **cover the entire sample**.
6. Cover the container with aluminum foil, wait until the gel solidifies. This can be done at room temperature or in the fridge.

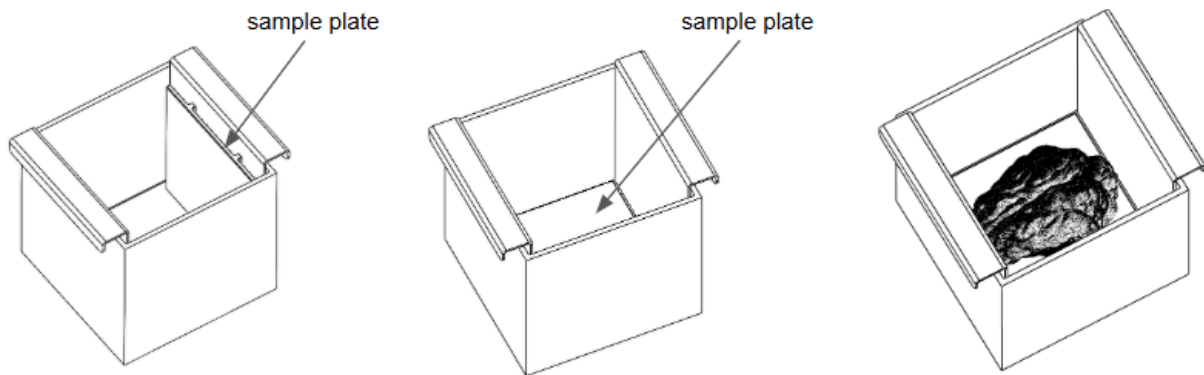

a, Coronal sectioning

b, Horizontal and sagittal sectioning
Figure 2 Toolkit assembly and sample placement

c, Sample placement

Formalin fixation

This process is to fix the gelatin with the tissue in formalin to prevent the sample from slipping out of the gel or deforming during sectioning.

1. Use a flat end lab scoop to gently cut the gel along the edge of the container, and lift the **lifting tray** from the container.
2. **Without** separating the gel from the **lifting tray**, place the lifting tray/gel in the **fixation container**.
3. Pour the neutral buffered formalin solution into the fixation container to **fully immerse the gel**. Close the airtight lid.
4. Place the **fixation container** on a shaker. The fixing time depends on the size of the sample. Follow the guidelines as below:

Sample type examples	Marmoset brain	Human brain slab	Human brain hemisphere
Fixing time	24 hours	48 hours	1 week

5. Wash the sample by changing the formalin solution to 1xPBS solution.
6. After sufficient washing, gently remove the gel and the sample plate from the lifting tray by using a blade or a flat end lab scoop. Now the sample is ready for sectioning.

Sample mounting on the Megatome

1. Power on the Megatome. On the Megatome touchscreen, select the **Home** button. The sample platform will move to its home position.
2. Slide the sample plate onto the Megatome sample platform in the same direction as shown in Figure 3. The sample plate is secured magnetically. If the sample plate is placed incorrectly, it will not be secured in place.
3. Bring the sample to the start position for sectioning using the Sample Positioning functions on the Megatome user interface.
4. Follow the Auto-Sectioning instructions in the [Megatome User's Manual](#) to proceed with the operation.

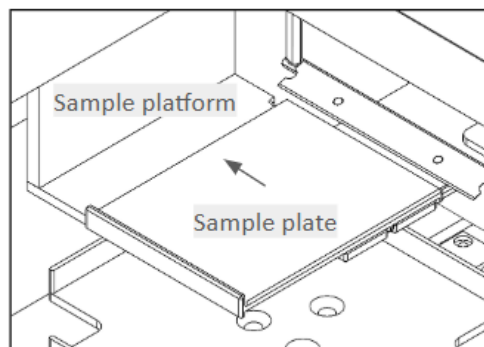

Figure 3 Sample plate mounting on the Megatome